



SERIE  
**VH**

FH

BAH

TA.CP

TA

MOx

HT

7-1

**VH**

TSI/TSX

T

MT-TC-TC3



Le teste multiple ad assi variabili raggiungono velocità di 4000 rpm, forando fino a 25 mm e maschiando M20. Il corpo testa è in lega di alluminio, ingranaggi e mandrini in acciaio trattati termicamente e rettificati per una maggiore precisione e resistenza all'usura. Disponibili in 31 differenti modelli, a 2,3,4 mandrini o con 1 solo mandrino decentrato, coprono interassi variabili da un minimo di 12 mm ad un massimo di 300 mm. Soluzioni personalizzate sono comunque sempre possibili anche in questa fascia di teste standard. L'utilizzo principale è su macchine o unità foratrici e maschiatrici, raramente su macchine CNC.



*The variable axis multispindle heads are able to achieve a speed of 4000 rpm, drilling up to 25 mm and tapping M20. The head body is made of aluminium alloy, the gears and spindles are made of steel which has undergone heat treatment and has been ground for greater precision and wear resistance. Available in 31 different models, with 2,3,4 spindles or just one decentralised spindle, they cover a range of centre distances from minimum 12 mm to maximum 300 mm. Customised solutions are in any case also available within this range of standard heads. They are mainly used on drilling and tapping units, but rarely on CNC machines.*





# VH04

TESTE MULTIPLE AD ASSI VARIABILI - VARIABLE AXIS HEADS

**05** CAPACITÀ FORATURA  
DRILLING CAPACITY

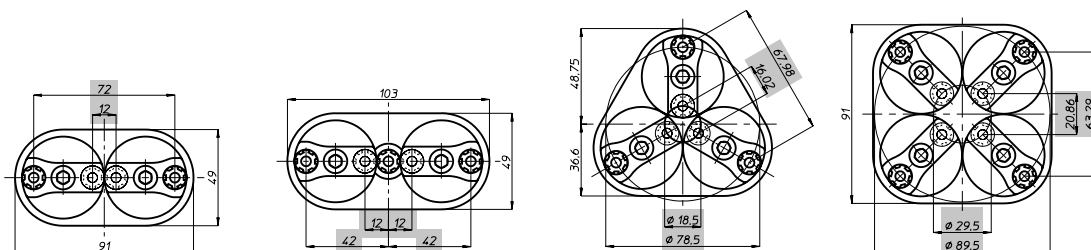
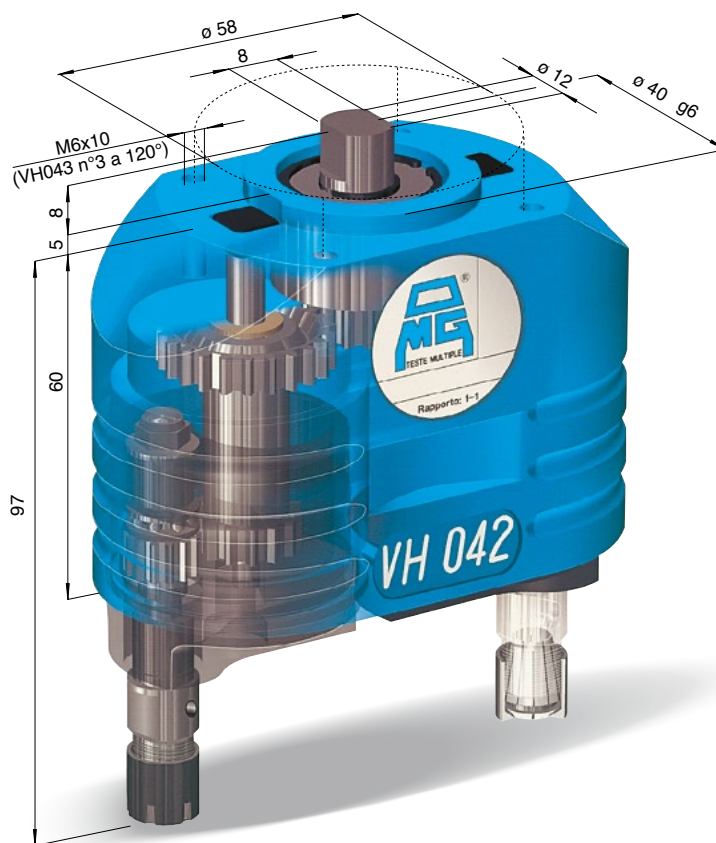

TESTA MODELLO HEAD TYPE	VH 042	VH 043 L	VH 043	VH 044
ARTICOLO ITEM	VH 042 P	VH 043 LP	VH 043 P	VH 044 P
ATTACCO UTENSILE SPINDLE TYPE	ER 8 - max ø 5			
ARTICOLO ITEM				
ATTACCO UTENSILE SPINDLE TYPE				
N. MANDRINI SPINDLES NR.	2	3	3	4
CAMPO DI LAVORO MIN. CENTRE DISTANCES MIN.	12	12+12	ø 18,5	ø 29,5
CAMPO DI LAVORO MAX. CENTRE DISTANCES MAX.	72	42+42	ø 78,5	ø 89,5
CAPACITÀ FORATURA DRILLING CAPACITY	ACCIAIO/STILL Rm 500 N/mm <sup>2</sup> - ø 4   GHISA/CAST IRON GG25 - ø 5			
MASCHIATURA TAPPING	M 3			
RAPPORTO RATIO	1 - 1			
VELOCITÀ RPM	4.000			
PESO WEIGHT	0,95 kg	1,05 kg	1,4 kg	1,9 kg





NOTA:  
NOTE:

A.B.C.D. DATI MACCHINA  
A.B.C.D. MACHINE FEATURES

# VH04

MANICOTTO DI COLLEGAMENTO • CONNECTION COLLAR

DIN 238	CODICE
B 10	011277
B 12	011278
B 16	011279
B 18	011280

DIN 55058	CODICE
16	525405
20	525406
28	525407

DIN 228	CODICE
cm 1	011115
cm 2	011120
cm 3	011125



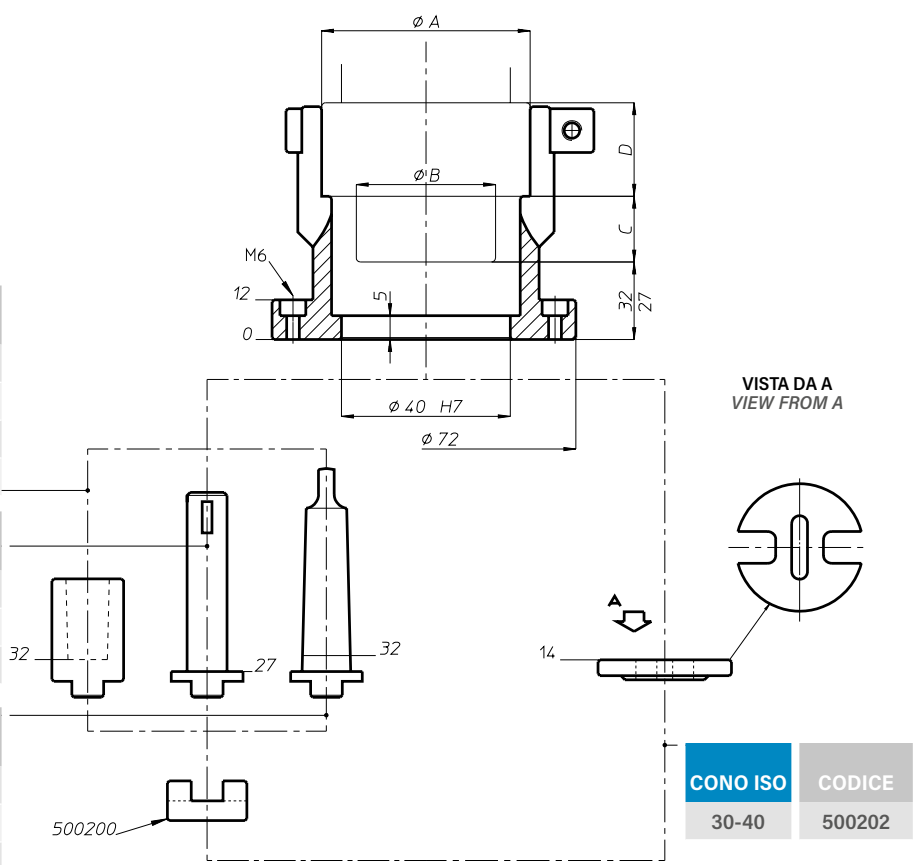

# VH06

TESTE MULTIPLE AD ASSI VARIABILI - VARIABLE AXIS HEADS



CAPACITÀ FORATURA  
DRILLING CAPACITY

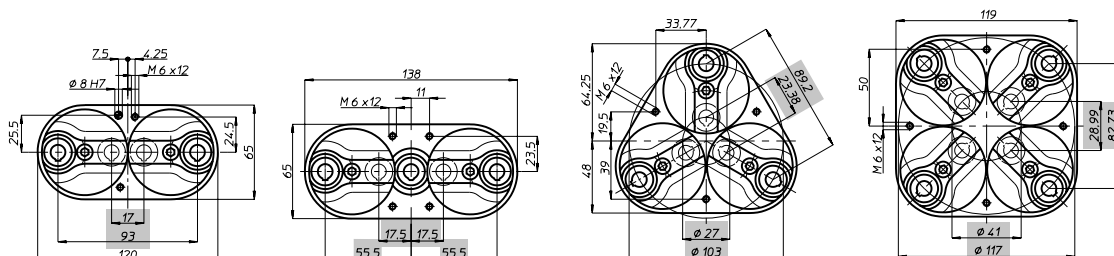
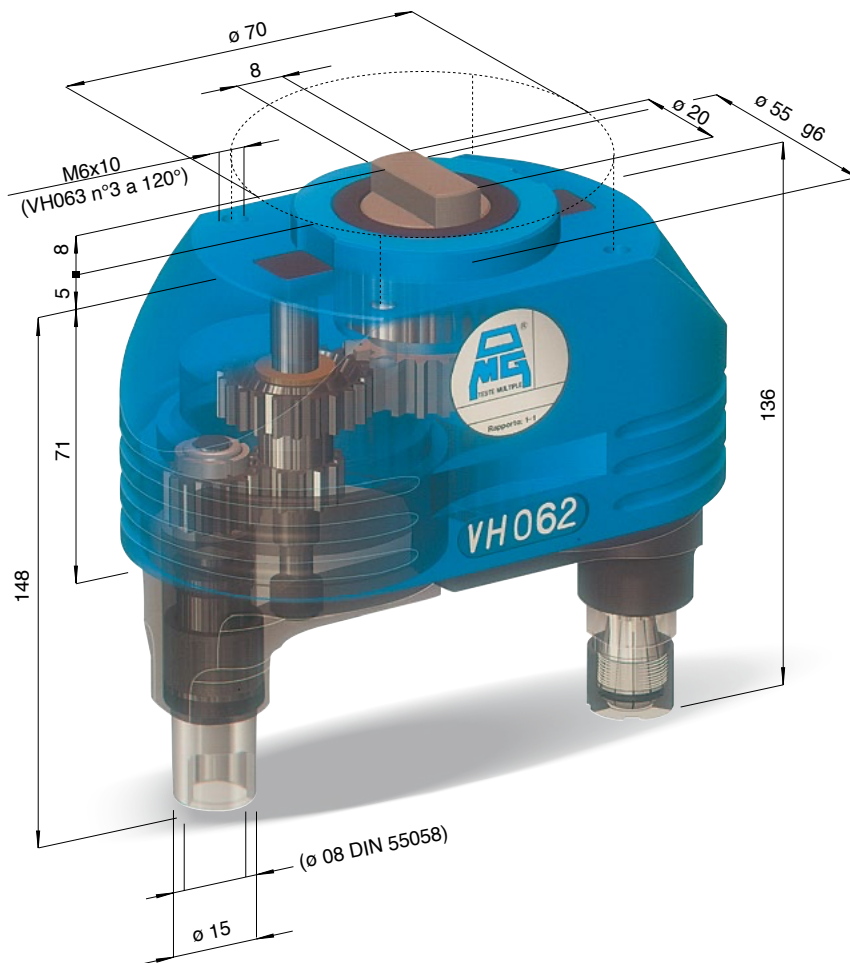

TESTA MODELLO  
HEAD TYPE

VH 062

VH 063 L

VH 063

VH 064

ARTICOLO  
ITEM

VH 062 P

VH 063 LP

VH 063 P

VH 064 P

ATTACCO UTENSILE  
SPINDLE TYPE

ER 11 - max  $\phi 7$

ARTICOLO  
ITEM

VH 062 D

VH 063 LD

VH 063 D

VH 064 D

ATTACCO UTENSILE  
SPINDLE TYPE

DIN55058 -  $\phi 8$

N. MANDRINI  
SPINDLES NR.

2

3

3

4

CAMPO DI LAVORO MIN.  
CENTRE DISTANCES MIN.

17

17,5 + 17,5

$\phi 27$

$\phi 41$

CAMPO DI LAVORO MAX.  
CENTRE DISTANCES MAX.

93

55,5 + 55,5

$\phi 103$

$\phi 117$

CAPACITÀ FORATURA  
DRILLING CAPACITY

ACCIAIO/STILL Rm 500 N/mm<sup>2</sup> -  $\phi 6$  | GHISA/CAST IRON GG25 -  $\phi 7$

MASCHIATURA  
TAPPING

M 5

RAPPORTO  
RATIO

1 - 1

VELOCITÀ  
RPM

4.000

PESO  
WEIGHT

1,65 kg

1,95 kg

2,3 kg

3,1 kg



NOTA:  
NOTE:

A.B.C.D. DATI MACCHINA  
A.B.C.D. MACHINE FEATURES

# VH06

MANICOTTO DI COLLEGAMENTO - CONNECTION COLLAR

DIN 238	CODICE
B 10	011277
B 12	011278
B 16	011279
B 18	011280
B 22	011281
B 24	011282

DIN 55058	CODICE
16	525405
20	525406
28	525407
36	525408

DIN 228	CODICE
cm 1	011115
cm 2	011120
cm 3	011125
cm 4	011130
cm 5	011135

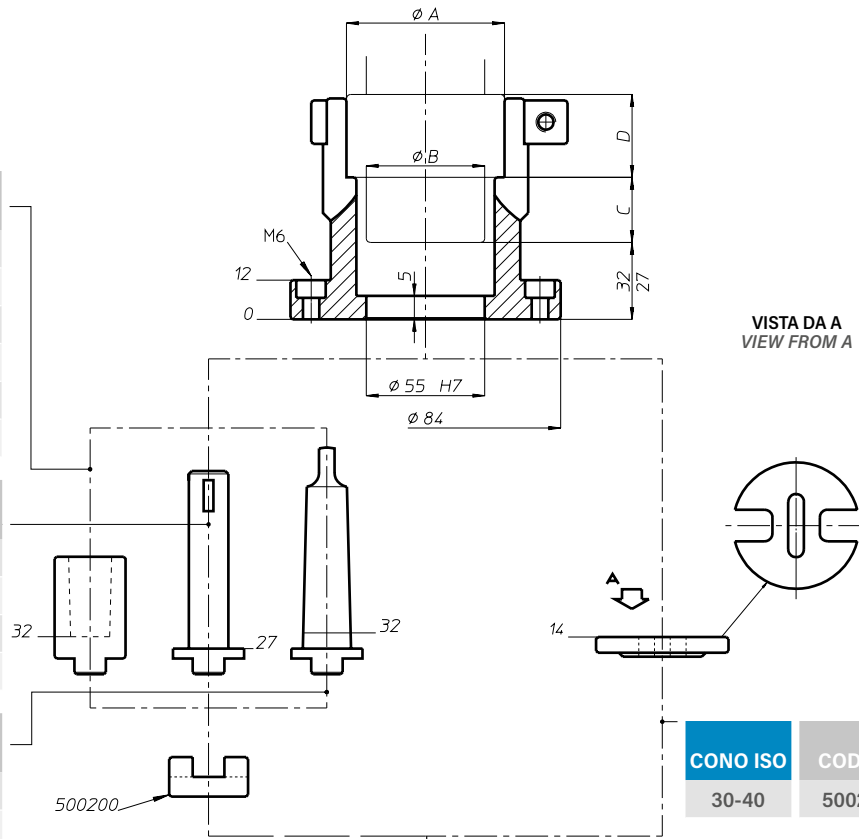

CONO ISO	CODICE
30-40	500202

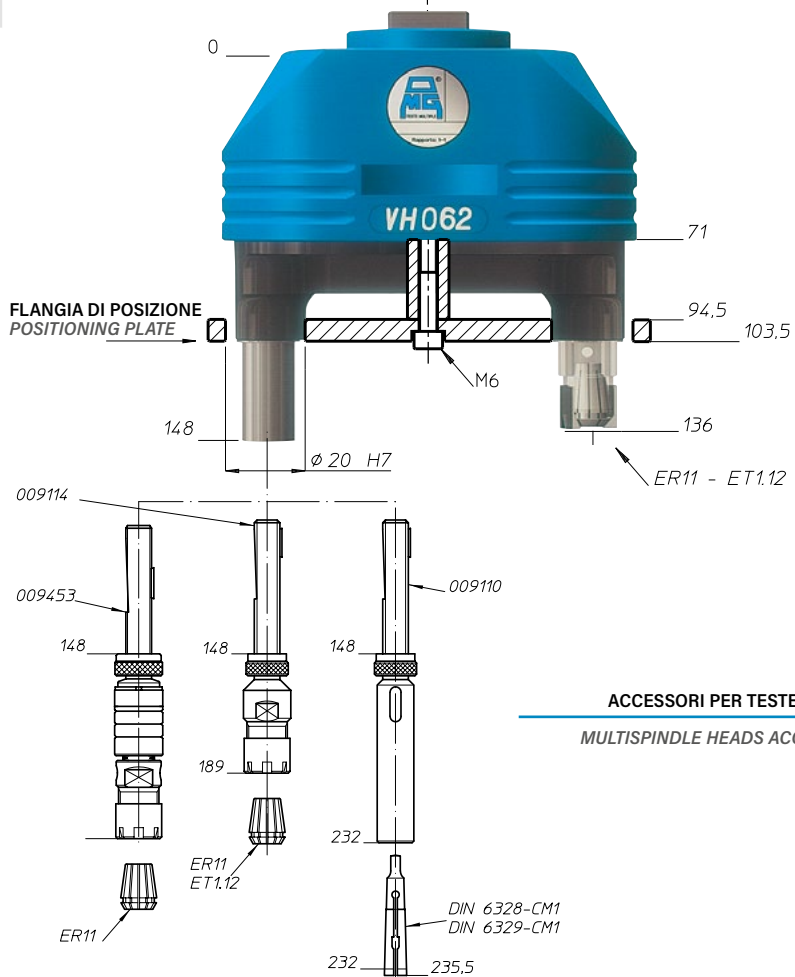

FH

BAH

TA.CP

TA

MOX

HT

7-6

VH

TSI/TSX

T

MT-TC-TC3





# VH08

TESTE MULTIPLE AD ASSI VARIABILI - VARIABLE AXIS HEADS



CAPACITÀ FORATURA  
DRILLING CAPACITY

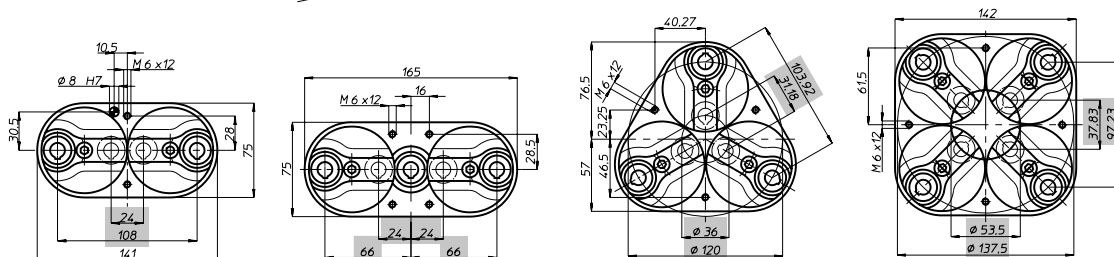
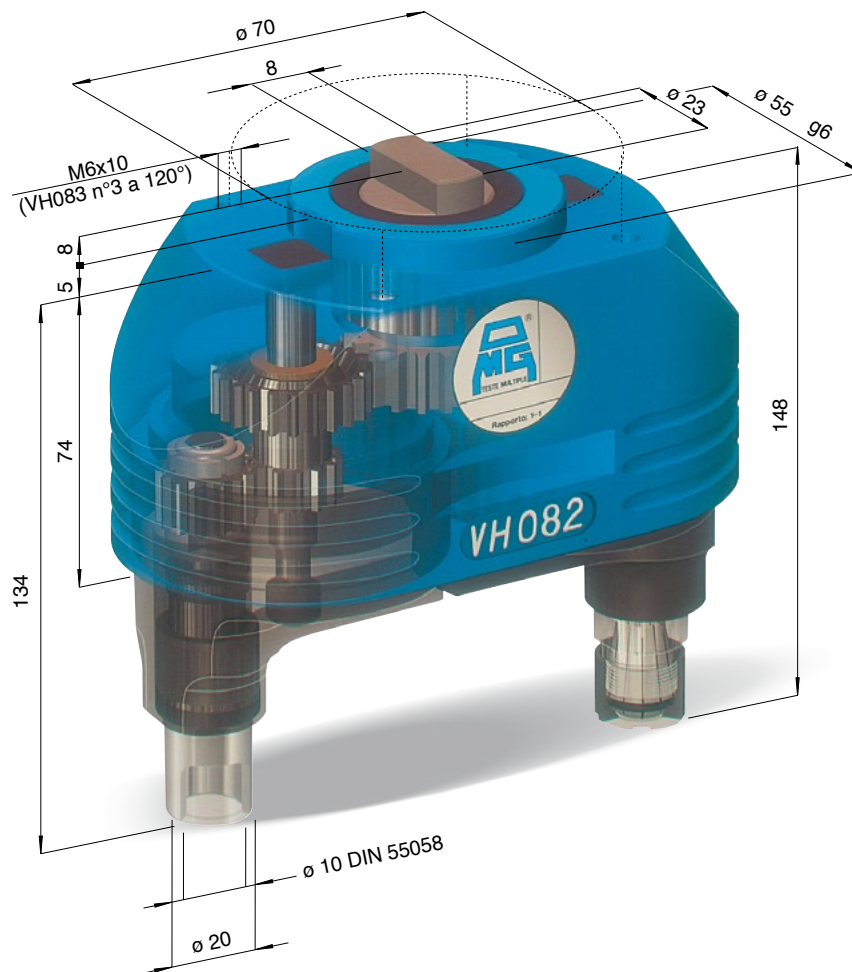

TESTA MODELLO  
HEAD TYPE

VH 082

VH 083 L

VH 083

VH 084

ARTICOLO  
ITEM

VH 082 P

VH 083 LP

VH 083 P

VH 84 P

ATTACCO UTENSILE  
SPINDLE TYPE

ER 16 - max ø 10

ARTICOLO  
ITEM

VH 082 D

VH 083 LD

VH 083 D

VH 84 D

ATTACCO UTENSILE  
SPINDLE TYPE

DIN55058 - ø 10

N. MANDRINI  
SPINDLES NR.

2

3

3

4

CAMPO DI LAVORO MIN.  
CENTRE DISTANCES MIN.

24

24 + 24

ø 36

ø 53,5

CAMPO DI LAVORO MAX.  
CENTRE DISTANCES MAX.

108

66 + 66

ø 120

ø 137,5

CAPACITÀ FORATURA  
DRILLING CAPACITY

ACCIAIO/STILL Rm 500 N/mm<sup>2</sup> - ø 8 | GHISA/CAST IRON GG25 - ø 10

MASCHIATURA  
TAPPING

M 6

RAPPORTO  
RATIO

1 - 1

VELOCITÀ  
RPM

4.000

PESO  
WEIGHT

2,2 kg

2,9 kg

3,4 kg

4,6 kg

NOTA:  
NOTE:

A.B.C.D. DATI MACCHINA

A.B.C.D. MACHINE FEATURES

# VH08

MANICOTTO DI COLLEGAMENTO • CONNECTION COLLAR

DIN 238	CODICE
B 10	011277
B 12	011278
B 16	011279
B 18	011280
B 22	011281
B 24	011282

DIN 55058	CODICE
16	525405
20	525406
28	525407
36	525408

DIN 228	CODICE
cm 1	011115
cm 2	011120
cm 3	011125
cm 4	011130
cm 5	011135

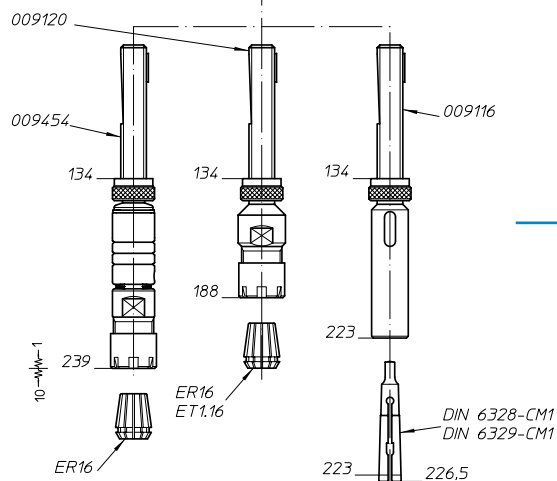
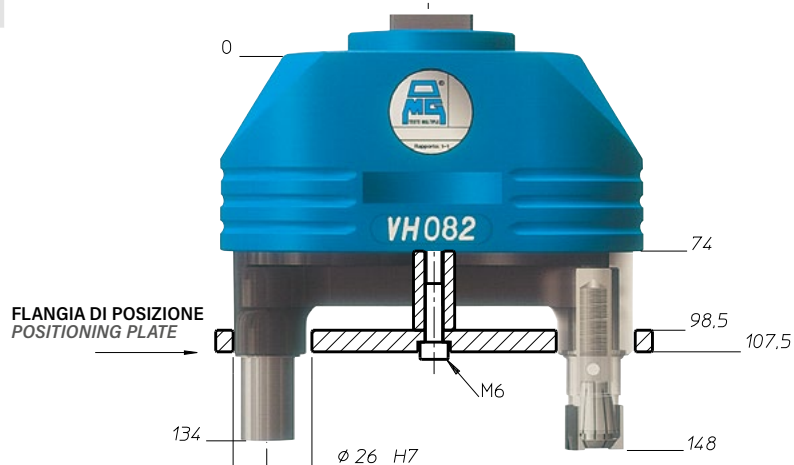
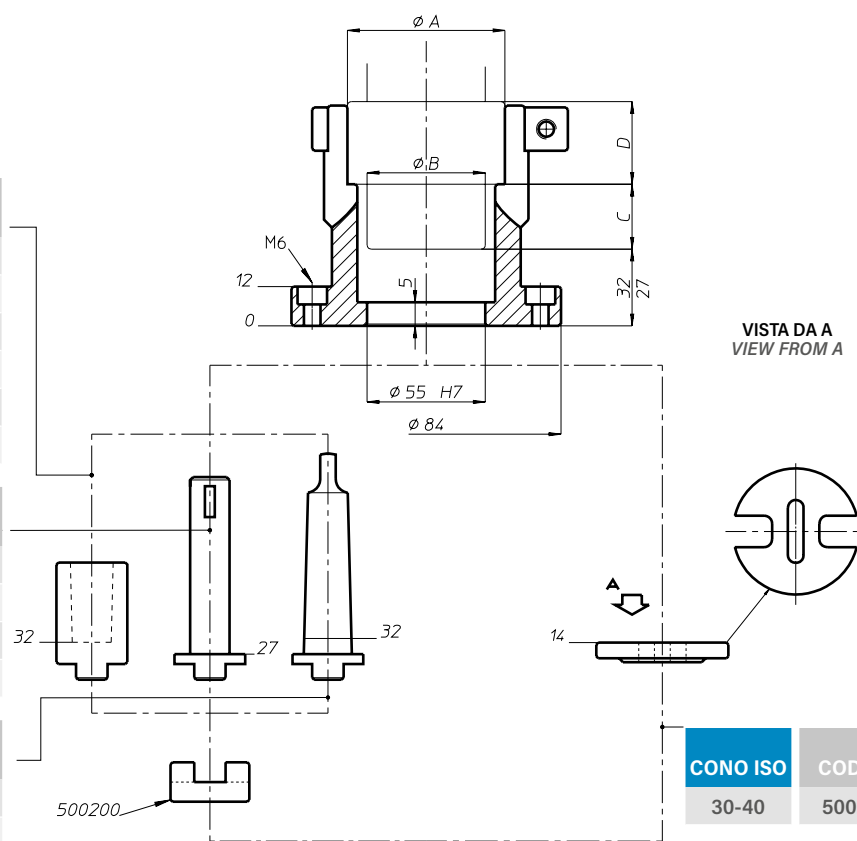

ACCESSORI PER TESTE MULTIPLE  
MULTISPINDLE HEADS ACCESSORIES

FH  
BAH  
TA.CP  
TA  
MOX  
HT

7-8

VH

TSI/TSX

T

MT-TC-TC3







# VH10

TESTE MULTIPLE AD ASSI VARIABILI - VARIABLE AXIS HEADS

012

CAPACITÀ FORATURA  
DRILLING CAPACITY

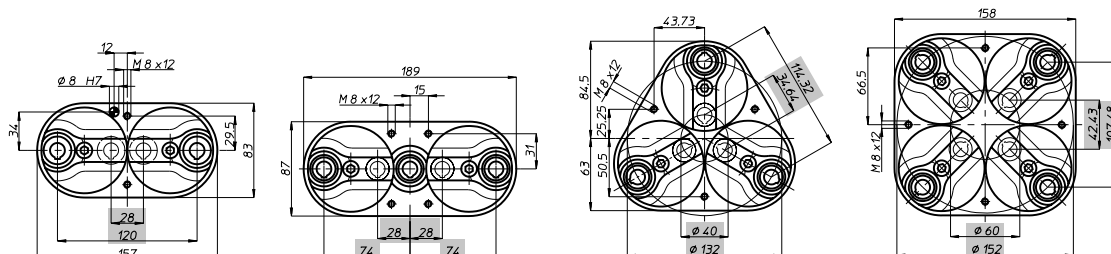
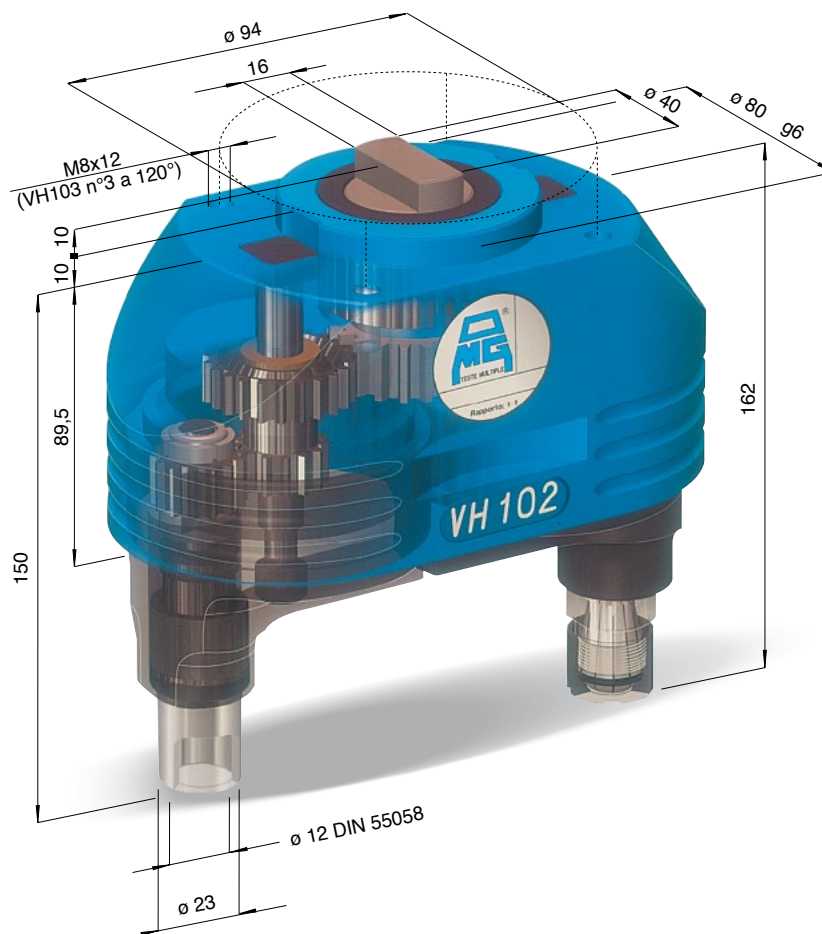

TESTA MODELLO HEAD TYPE	VH 102	VH 103 L	VH 103	VH 104
ARTICOLO ITEM	VH 102 P	VH 103 LP	VH 103 P	VH 104 P
ATTACCO UTENSILE SPINDLE TYPE	ER 16 - max ø 10			
ARTICOLO ITEM	VH 102 D	VH 103 LD	VH 103 D	VH 104 D
ATTACCO UTENSILE SPINDLE TYPE	DIN55058 - ø 12			
N. MANDRINI SPINDLES NR.	2	3	3	4
CAMPO DI LAVORO MIN. CENTRE DISTANCES MIN.	28	28 + 28	ø 40	ø 60
CAMPO DI LAVORO MAX. CENTRE DISTANCES MAX.	120	74 + 74	ø 132	ø 152
CAPACITÀ FORATURA DRILLING CAPACITY	ACCIAIO/STILL Rm 500 N/mm <sup>2</sup> - ø 10   GHISA/CAST IRON GG25 - ø 12			
MASCHIATURA TAPPING	M 8			
RAPPORTO RATIO	1 - 1			
VELOCITÀ RPM	3.500			
PESO WEIGHT	3,5 kg	4,9 kg	4,9 kg	7,2 kg

NOTA:  
NOTE:

A.B.C.D. DATI MACCHINA  
A.B.C.D. MACHINE FEATURES

# VH10

MANICOTTO DI COLLEGAMENTO • CONNECTION COLLAR

DIN 238	CODICE
B 10	011277
B 12	011278
B 16	011279
B 18	011280
B 22	011281
B 24	011282

DIN 55058	CODICE
16	525405
20	525406
28	525407
36	525408

DIN 228	CODICE
cm 1	011115
cm 2	011120
cm 3	011125
cm 4	011130
cm 5	011135

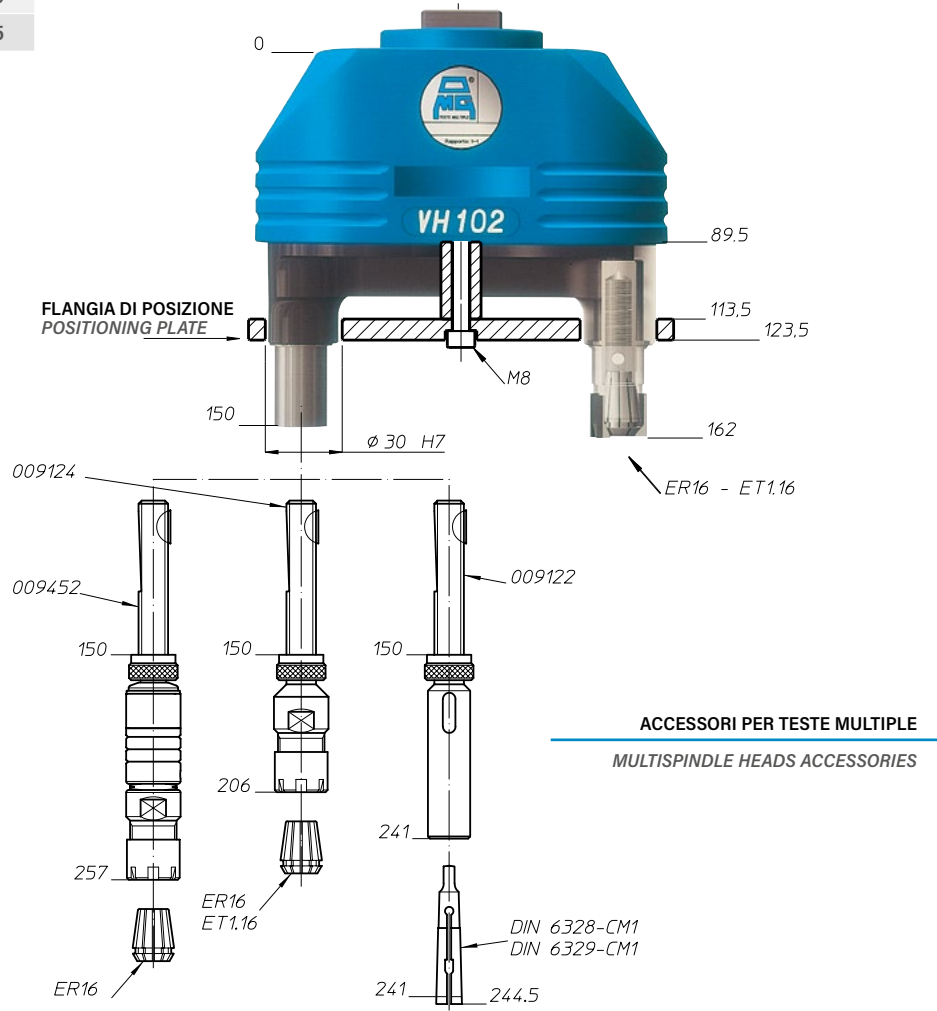
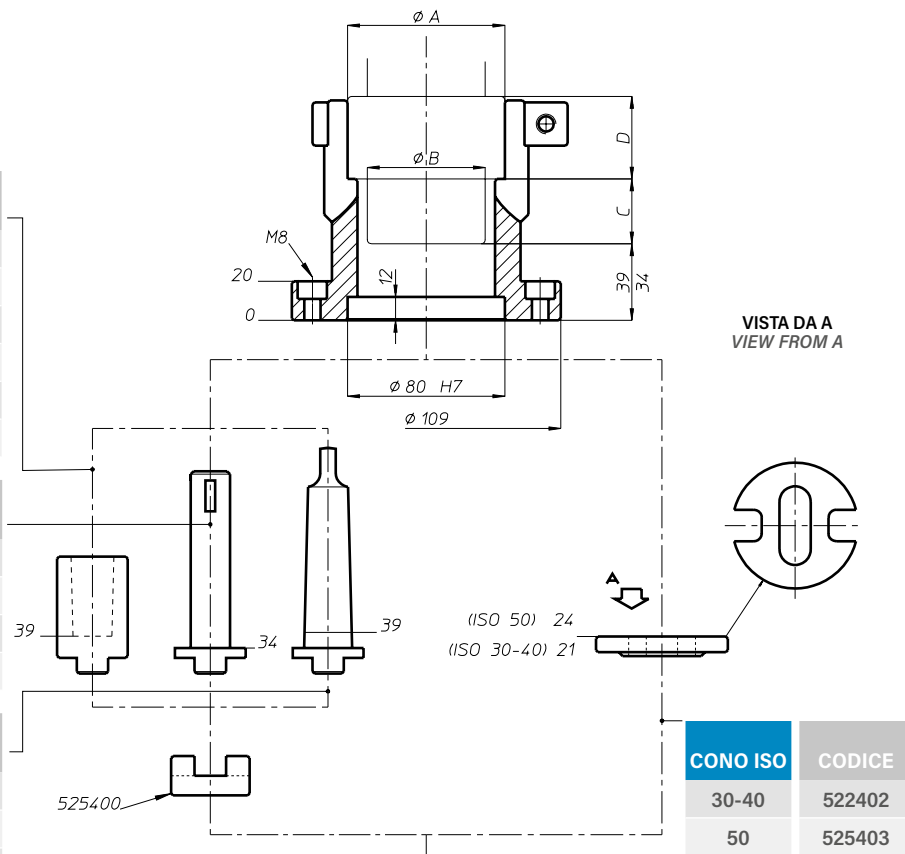

FH

BAH

TA.CP

TA

MOX

HT

VH

TSI/TSX

T

MT-TC-TC3



7-10



# VH13

TESTE MULTIPLE AD ASSI VARIABILI - VARIABLE AXIS HEADS

014

CAPACITÀ FORATURA  
DRILLING CAPACITY

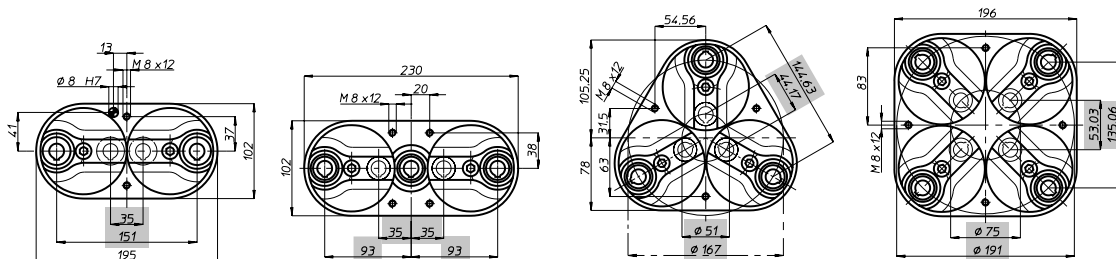
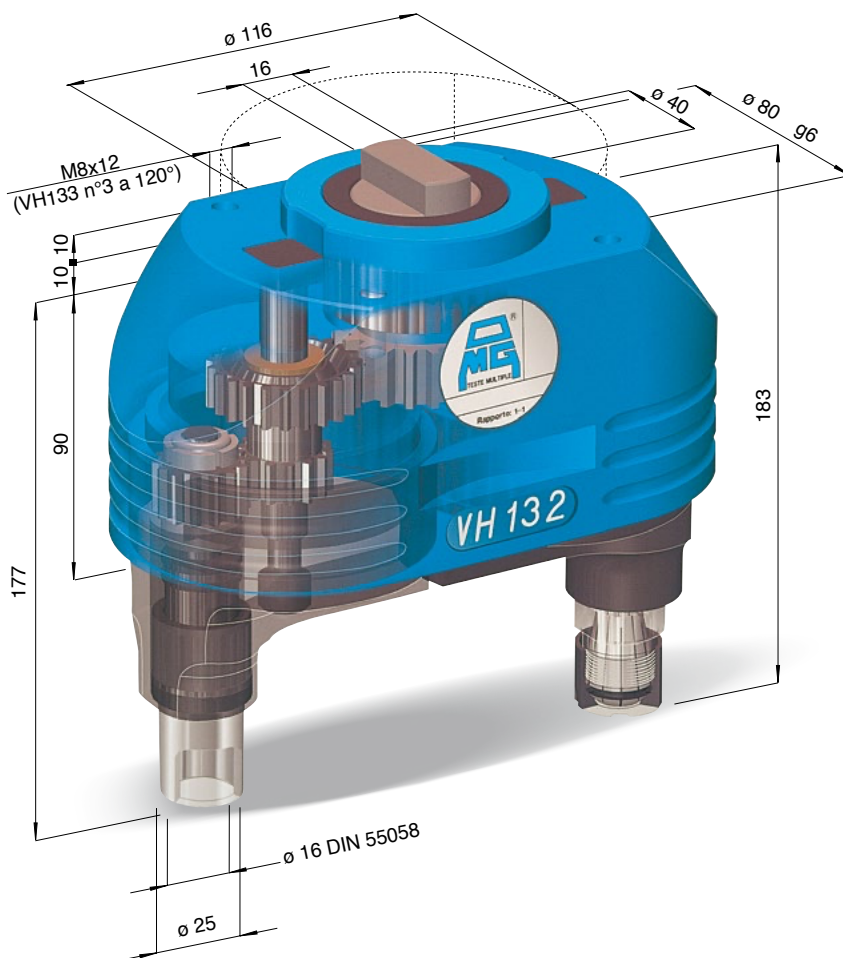

TESTA MODELLO  
HEAD TYPE

VH 132

VH 133 L

VH 133

VH 134

ARTICOLO  
ITEM

VH 132 P

VH 133 LP

VH 133 P

VH 134 P

ATTACCO UTENSILE  
SPINDLE TYPE

ER 20 - max  $\varnothing$  13

ARTICOLO  
ITEM

VH 132 D

VH 133 LD

VH 133 D

VH 134 D

ATTACCO UTENSILE  
SPINDLE TYPE

DIN55058 -  $\varnothing$  16

N. MANDRINI  
SPINDLES NR.

2

3

3

4

CAMPO DI LAVORO MIN.  
CENTRE DISTANCES MIN.

35

35 + 35

$\varnothing$  51

$\varnothing$  75

CAMPO DI LAVORO MAX.  
CENTRE DISTANCES MAX.

151

93 + 93

$\varnothing$  167

$\varnothing$  191

CAPACITÀ FORATURA  
DRILLING CAPACITY

ACCIAIO/STILL Rm 500 N/mm<sup>2</sup> -  $\varnothing$  13 | GHISA/CAST IRON GG25 -  $\varnothing$  14

MASCHIATURA  
TAPPING

M 12

RAPPORTO  
RATIO

1 - 1

VELOCITÀ  
RPM

3.000

PESO  
WEIGHT

5,3 kg

7,2 kg

7 kg

10,8 kg



NOTA:  
NOTE:

A.B.C.D. DATI MACCHINA  
A.B.C.D. MACHINE FEATURES

# VH13

MANICOTTO DI COLLEGAMENTO - CONNECTION COLLAR

DIN 238	CODICE
B 16	011279
B 18	011280
B 22	011281
B 24	011282

DIN 55058	CODICE
16	525405
20	525406
28	525407
36	525408

DIN 228	CODICE
cm 2	011120
cm 3	011125
cm 4	011130
cm 5	011135

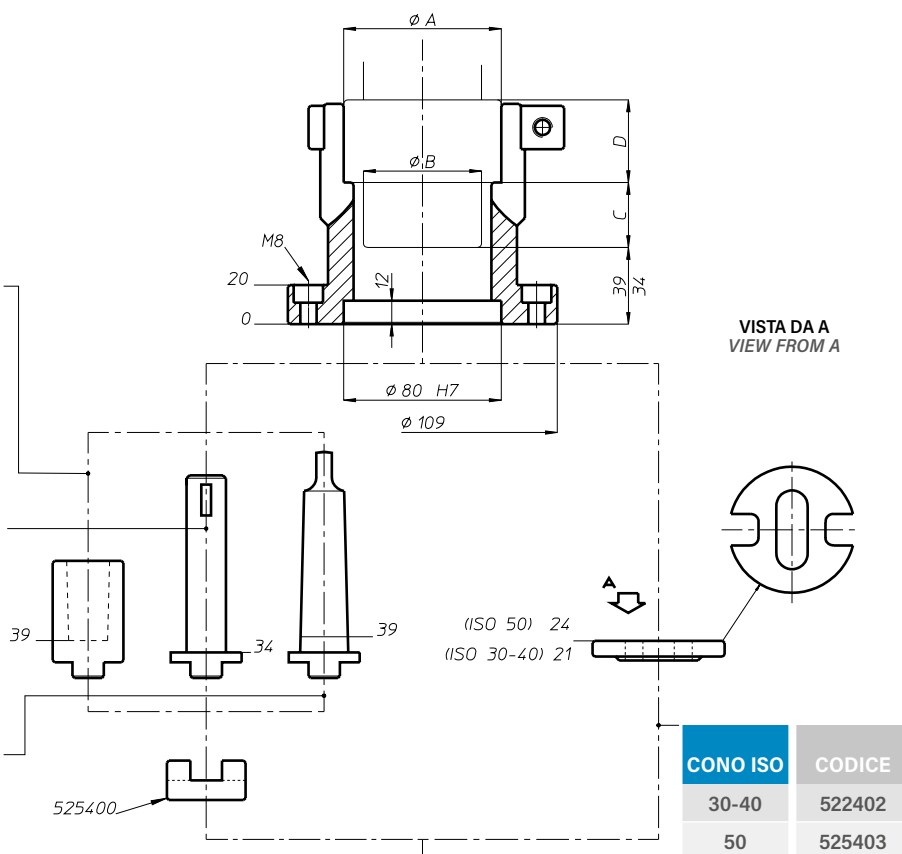

**Nota:**

L'utilizzo di questo accessorio richiede il mandrino preposto. La lunghezza degli accessori, comprensivi di manicotto attaccorapido, aumenta di mm 9,5.

**Note:**

The use of this accessory requires prearranged spindle. The length of this accessories whit quick connection sleeve increases of mm 9,5.

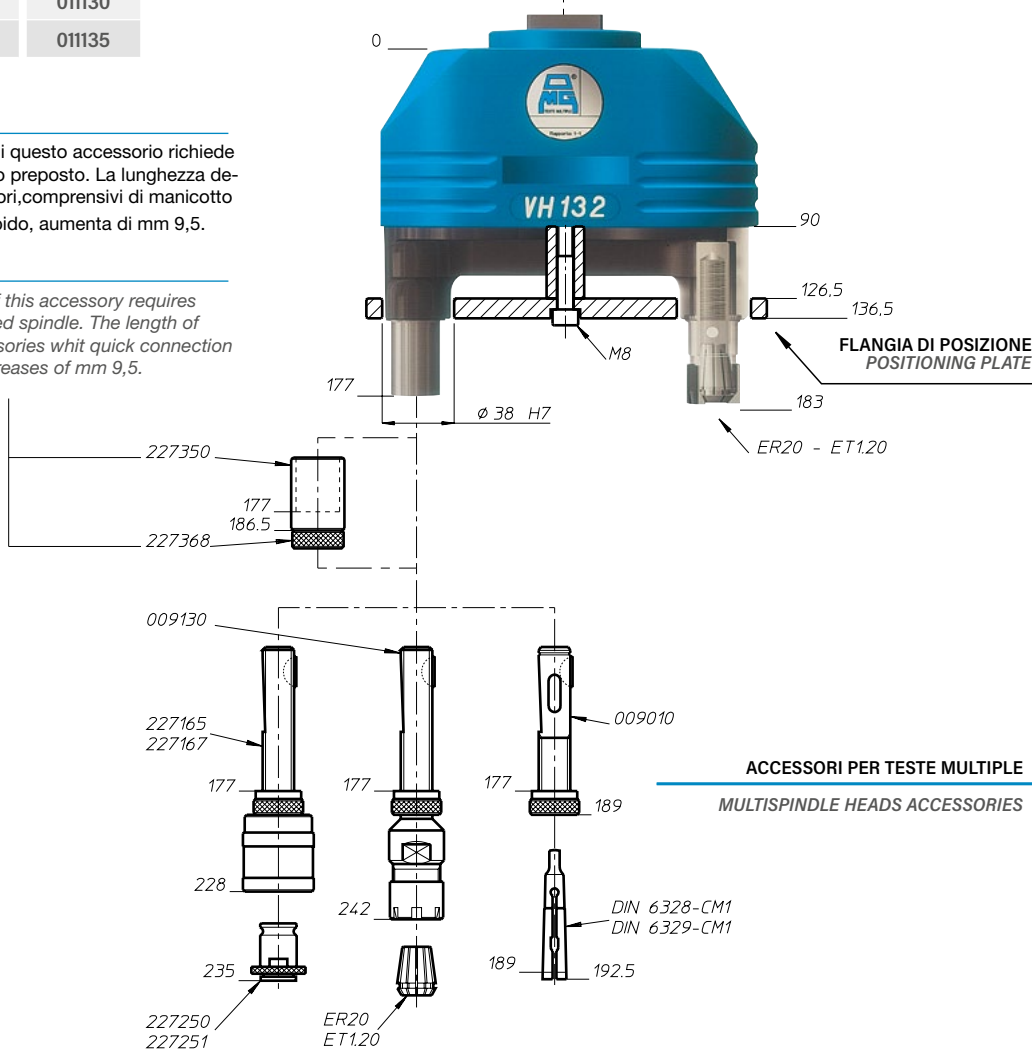

ACCESSORI PER TESTE MULTIPLE  
MULTISPINDLE HEADS ACCESSORIES

FH

BAH

TA.CP

TA

MOX

HT

7-12

VH

TSI/TSX

T

MT-TC-TC3





# VH18

TESTE MULTIPLE AD ASSI VARIABILI - VARIABLE AXIS HEADS



CAPACITÀ FORATURA  
DRILLING CAPACITY

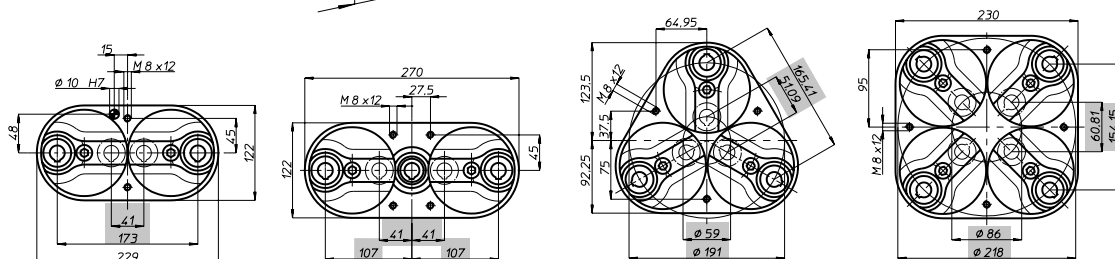
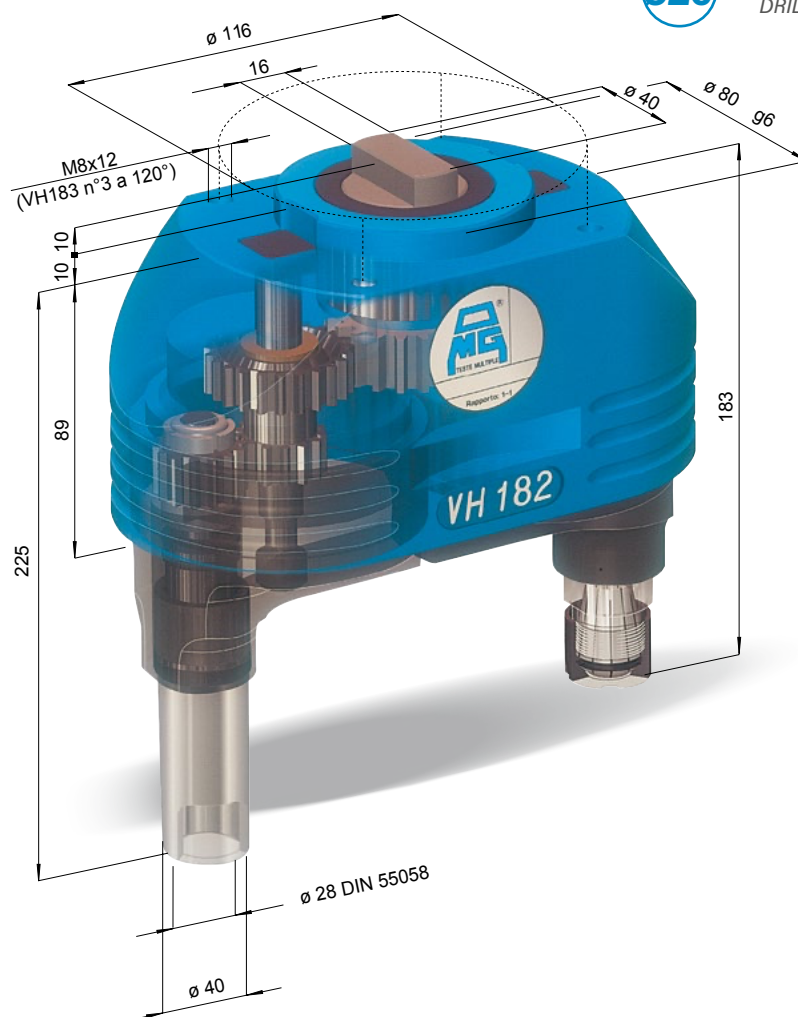

TESTA MODELLO  
HEAD TYPE

VH 182

VH 183 L

VH 183

VH 184

ARTICOLO  
ITEM

VH 182 P

VH 183 LP

VH 183 P

VH 184 P

ATTACCO UTENSILE  
SPINDLE TYPE

ER 25 - max Ø 16

ARTICOLO  
ITEM

VH 182 D

VH 183 LD

VH 183 D

VH 184 D

ATTACCO UTENSILE  
SPINDLE TYPE

DIN55058 - Ø 28

N. MANDRINI  
SPINDLES NR.

2

3

3

4

CAMPO DI LAVORO MIN.  
CENTRE DISTANCES MIN.

41

41 + 41

Ø 59

Ø 86

CAMPO DI LAVORO MAX.  
CENTRE DISTANCES MAX.

173

107 + 107

Ø 191

Ø 218

CAPACITÀ FORATURA  
DRILLING CAPACITY

ACCIAIO/STILL Rm 500 N/mm<sup>2</sup> - Ø 18 | GHISA/CAST IRON GG25 - Ø 20

MASCHIATURA  
TAPPING

M 14

RAPPORTO  
RATIO

1 - 1

VELOCITÀ  
RPM

2.500

PESO  
WEIGHT

8,3 kg

10,75 kg

12 kg

15,75 kg





NOTA:  
NOTE:

A.B.C.D. DATI MACCHINA  
A.B.C.D. MACHINE FEATURES

# VH18

MANICOTTO DI COLLEGAMENTO • CONNECTION COLLAR

DIN 238	CODICE
B 16	011279
B 18	011280
B 22	011281
B 24	011282

DIN 55058	CODICE
16	525405
20	525406
28	525407
36	525408

DIN 228	CODICE
cm 3	011125
cm 4	011130
cm 5	011135

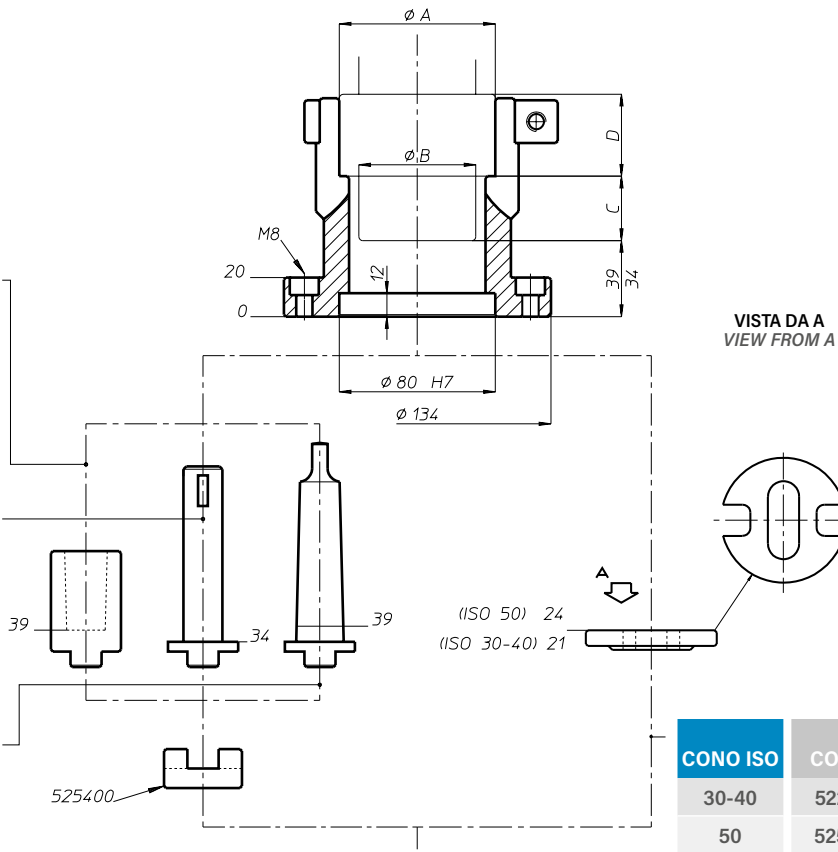

**Nota:**

La lunghezza degli accessori, comprensivi di manicotto attacco rapido, aumenta di mm 10.

**Note:**

The length of this accessories whit quick connection sleeve increases of mm 10.

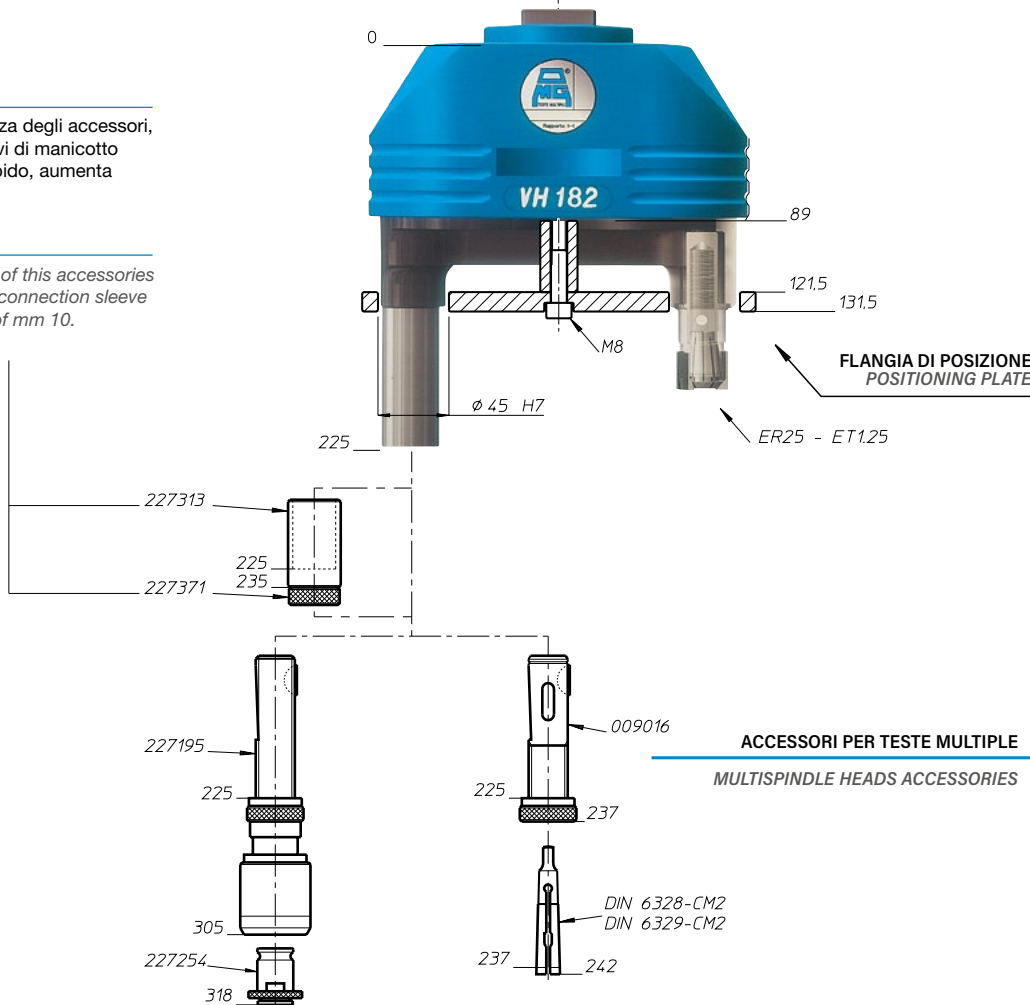

FH

BAH

TA.CP

TA

MOX

HT

7-14

VH

TSI/TSX

T

MT-TC-TC3





# VH25

TESTE MULTIPLE AD ASSI VARIABILI - VARIABLE AXIS HEADS

Ø28

CAPACITÀ FORATURA  
DRILLING CAPACITY

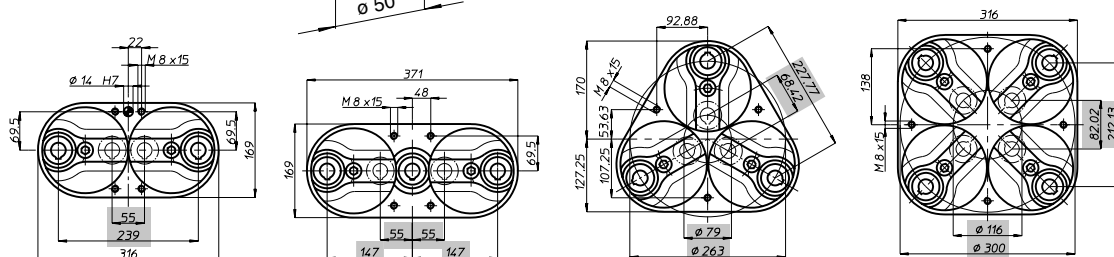
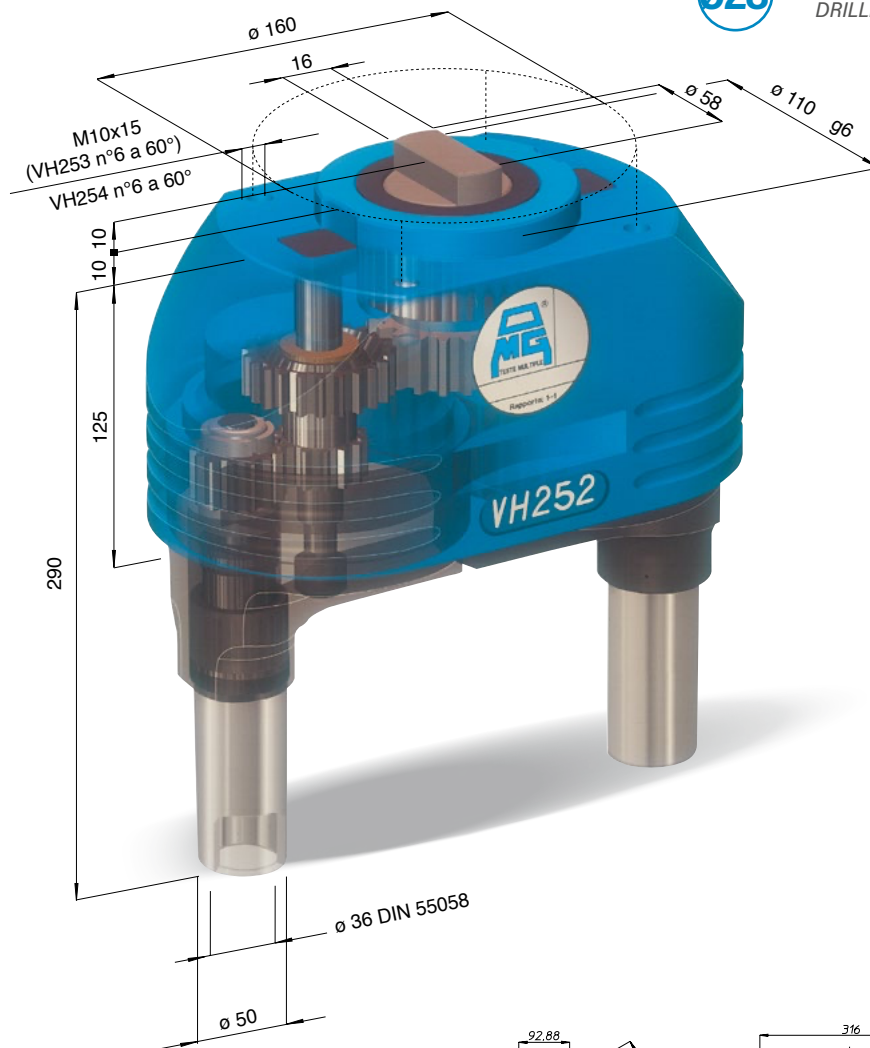

TESTA MODELLO  
HEAD TYPE

VH 252

VH 253 L

VH 253

VH 254

ARTICOLO  
ITEM

ATTACCO UTENSILE  
SPINDLE TYPE

ARTICOLO  
ITEM

VH 252 D

VH 253 LD

VH 253 D

VH 254 D

ATTACCO UTENSILE  
SPINDLE TYPE

DIN55058 - Ø 36

N. MANDRINI  
SPINDLES NR.

2

3

3

4

CAMPO DI LAVORO MIN.  
CENTRE DISTANCES MIN.

55

55 + 55

Ø 79

Ø 116

CAMPO DI LAVORO MAX.  
CENTRE DISTANCES MAX.

239

147 + 147

Ø 263

Ø 300

CAPACITÀ FORATURA  
DRILLING CAPACITY

ACCIAIO/STILL Rm 500 N/mm<sup>2</sup> - Ø 25 | GHISA/CAST IRON GG25 - Ø 28

MASCHIATURA  
TAPPING

M 20

RAPPORTO  
RATIO

1 - 1

VELOCITÀ  
RPM

2.000

PESO  
WEIGHT

27 kg

32 kg

39 kg

52 kg



NOTA:  
NOTE:

A.B.C.D. DATI MACCHINA  
A.B.C.D. MACHINE FEATURES

# VH25

MANICOTTO DI COLLEGAMENTO · CONNECTION COLLAR

DIN 238	CODICE
B 18	011280
B 22	011281
B 24	011282

DIN 55058	CODICE
16	525405
20	525406
28	525407
36	525408

DIN 228	CODICE
cm 3	011125
cm 4	011130
cm 5	011135

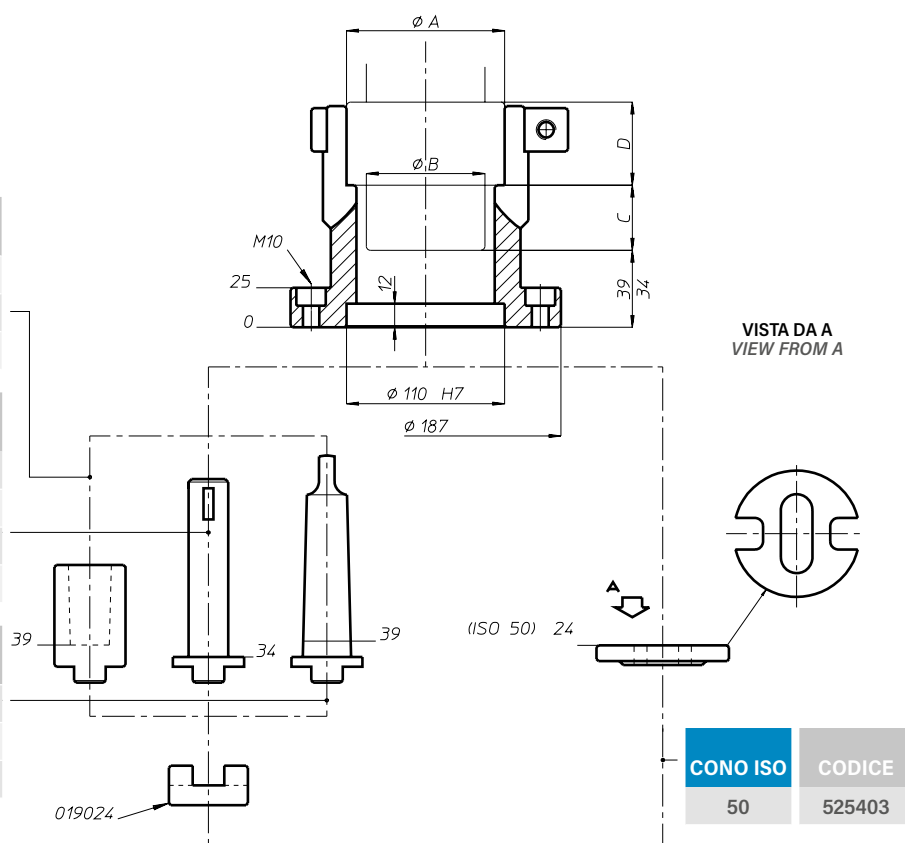

**Nota:**

L'utilizzo di questo accessorio richiede il mandrino preposto. La lunghezza degli accessori, comprensivi di manicotto attacco Rapido, aumenta di mm 9,5.

**Note:**

The use of this accessory requires prearranged spindle. The length of this accessories whit quick connection sleeve increases of mm 9,5.

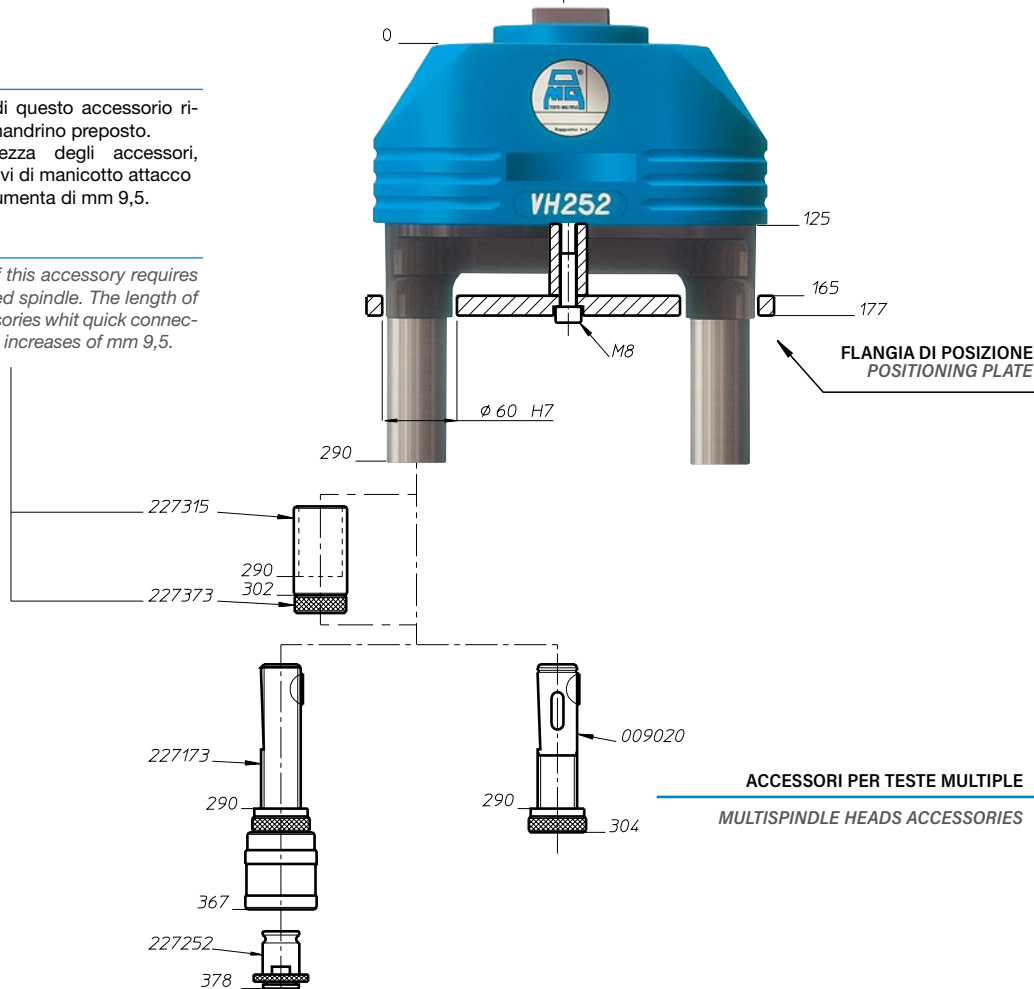









# REGOLAZIONI UTENSILI TOOL ADJUSTMENTS

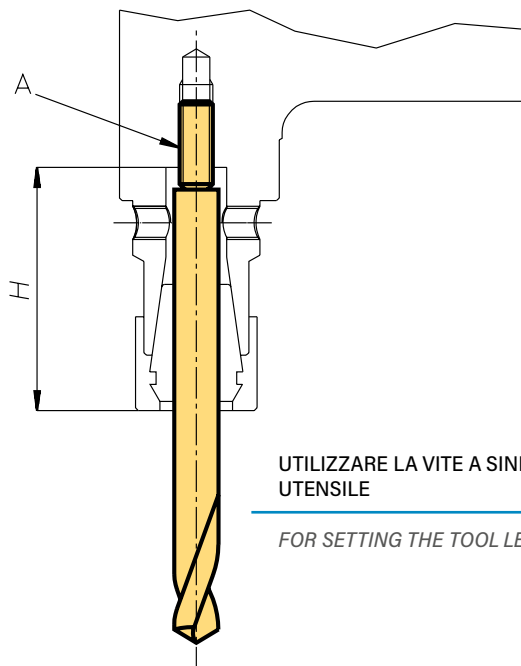

FORATURA CON PINZE ER  
DRILLING WITH ER COLLETS

UTILIZZARE LA VITE A SINISTRA PER REGISTRARE L'ALTEZZA UTENSILE

FOR SETTING THE TOOL LENGTH, USE THE LEFT SCREW A

TESTA MODELLO HEAD TYPE	VH 04	VH 06	VH 08	VH 10	VH 13	VH 18
H MAX	23	27	44	44	52	49

NOTA: nella testa VH04 e VH06 la vite A non è presente **NOTE:** in the head VH04 and VH06 there isn't the screw A

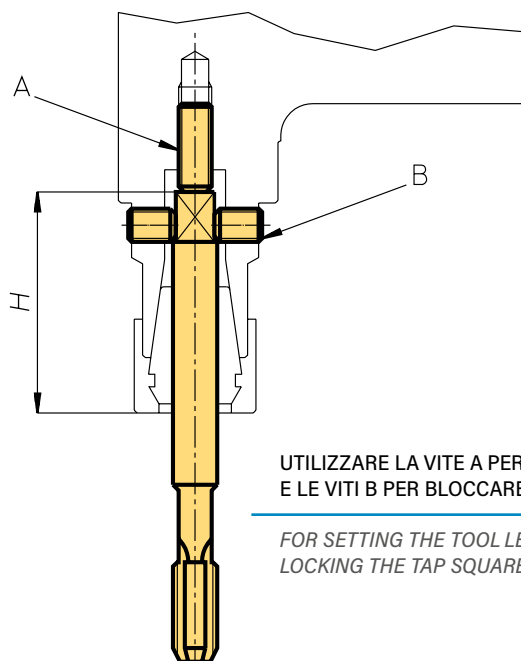

MASCHIATURA CON PINZE ER  
TAPPING WITH ER COLLETS

UTILIZZARE LA VITE A PER REGISTRARE L'ALTEZZA UTENSILE  
E LE VITI B PER BLOCCARE IL QUADRO DEL MASCHIO

FOR SETTING THE TOOL LENGTH, USE THE SCREW A;  
LOCKING THE TAP SQUARE WITH THE SCREWS B

TESTA MODELLO HEAD TYPE	VH 04	VH 06	VH 08	VH 10	VH 13	VH 18
H MAX	23	27	38	38	44	49

NOTA: nella testa VH04 e VH06 la vite A non è presente **NOTE:** in the head VH04 and VH06 there isn't the screw A

VH 042 LP  
 VH 042P R. 1-2  
 VH 062 LP  
 VH 062 LD  
 VH 062/1  
 VH 062P R.1-2  
 VH 062P CNC40  
 VH 063P CNC40  
 VH 064P CNC40  
 VH 064/3P  
 VH 081 P  
 VH 082 LP  
 VH 082 LD  
 VH 082 P R. 1-2  
 VH 082P CNC 40  
 VH 082PFM  
 VH 083 LP CNC40  
 VH 084P CNC 40  
 VH 084/3P  
 VH 102 LP  
 VH 102 LD  
 VH 102 P CNC 40  
 VH 102P R. 1-2  
 VH 102 PFM  
 VH 102-220 P  
 VH 102-300 P  
 VH 104D R.1-2  
 VH 104P CNC50  
 VH 132 LP  
 VH 132 LD  
 VH 132D CNC50  
 VH 132P CNC50  
 VH 132 W12  
 VH 132-260 D  
 VH 134P CNC50  
 VH 181 R.1-2  
 VH 182 LP  
 VH 182 LD  
 VH 182 W16  
 VH 182 P CNC 50  
 VH 182 P R.1-2  
 VH 182D R. 1-2  
 VH 183 L W16  
 VH 252 LD

n° 2 mandrini a pinza, min. 24 max. 84  
 n° 2 mandrini a pinza, min. 12 max. 72 rapp. 1-2  
 n° 2 mandrini a pinza, min. 35 max. 111  
 n° 2 mandrini DIN 55058-8 min. 35 max. 111  
 n° 1 mandrino a pinza, min. 8,5 max. 46,5  
 n° 2 mandrini a pinza min. 17 max. 93 rapp. 1-2, 067  
 n° 2 mandrini a pinza min. 17 max. 93 completa di cono ISO 40  
 n° 3 mandrini a 120° a pinza min. 27 max. 103 completa di cono ISO 40  
 n° 4 mandrini a 90° a pinza min. 41 max. 117 completa di cono ISO 40  
 n° 3 mandrini a pinza min. 41 max. 117  
 n° 1 mandrino a pinza min. 0 max. 42  
 n° 2 mandrini a pinza min. 48 max. 132  
 n° 2 mandrini DIN 55058 - 10 min. 48 max. 132  
 n° 2 mandrini a pinza min. 24 max. 108 rapp. 1-2,067  
 n° 2 mandrini a pinza min. 24 max. 108 completa di cono ISO 40  
 n° 2 mandrini a pinza min. 24 max. 108  
 fora/maschia  
 n° 3 mandrini in linea a pinza min. 24+24 max. 66+66 completa di cono ISO 40  
 n° 4 mandrini a pinza min. 53,5 max. 137,5 completa di cono ISO 40  
 n° 3 mandrini a pinza min. 53,5 max. 137,5  
 n° 2 mandrini a pinza min. 56 max. 148  
 n° 2 mandrini DIN 55058-12 min. 56 max. 148  
 n° 2 mandrini a pinza min. 28 max. 120 completa di cono ISO 40  
 n° 2 mandrini a pinza min. 28 max. 120 rapporto 1-2  
 n° 2 mandrini a pinza min. 28 max. 120  
 fora/maschia  
 n° 2 mandrini a pinza min. 128 max. 220  
 n° 2 mandrini a pinza min. 208 max. 300  
 n° 4 mandrini a 90° DIN 55058-12 min. 60 max. 152 rapp. 1-2  
 n° 4 mandrini a 90° a pinza min. 60 max. 152 completa di cono ISO 50  
 n° 2 mandrini a pinza min. 70 max. 186  
 n° 2 mandrini DIN 55058-16 min. 70 max. 186  
 n° 2 mandrini DIN 55058-16 min. 35 max. 151 completa di cono ISO 50  
 n° 2 mandrini a pinza min. 35 max. 151 completa di cono ISO 50  
 n° 2 mandrini foro cilindrico diam. 12 min. 35 max. 151  
 n° 2 mandrini DIN 55058-16 min. 144 max. 260  
 n° 4 mandrini a 90° a pinza, min. 75 max. 191 completa di cono ISO 50  
 n° 1 mandrino diam. 16 min. 16,5 max. 82,5 rapp. 1-2  
 n° 2 mandrini a pinza, min. 82 max. 214  
 n° 2 mandrini DIN 55058-28 min. 82 max. 214  
 n° 2 mandrini foro cilindrico diam. 16 min. 41 max. 173  
 n° 2 mandrini a pinza, min. 41 max. 173 completa di cono ISO 50  
 n° 2 mandrini a pinza, min. 41 max. 173 173 rapp. 1-2  
 n° 2 mandrini DIN 55058-28 min. 41 max. 173 rapp. 1-2  
 n° 3 mandrini foro cilindrico diam. 16 min. 41+41 max. 107+107  
 n° 2 mandrini DIN 55058-36 min. 110 max. 294

2 spindles for spring collets min. 24 max. 84  
 2 spindles for spring collets min. 12 max. 72 ratio 1-2  
 2 spindles for spring collets min. 35 max. 111  
 2 spindles DIN 55058-8 min. 35 max. 111  
 1 spindle for spring collets min. 8,5 max. 46,5  
 2 spindles for spring collets min. 17 max. 93 ratio 1-2,067  
 2 spindles for spring collets min. 17 max. 93 with shank ISO 40  
 3 spindles at 120° for spring collets min. 27 max. 103 with shank ISO 40  
 4 spindles at 90° for spring collets min. 41 max. 117 with shank ISO 40  
 3 spindles for spring collets min. 41 max. 117  
 1 spindle for spring collets min. 0 max. 42  
 2 spindles for spring collets min. 48 max. 132  
 2 spindles DIN 55058 - 10 min. 48 max. 132  
 2 spindles for spring collets min. 24 max. 108 ratio 1-2  
 2 spindles for spring collets min. 24 max. 108 with shank ISO 40  
 2 spindles for spring collets min. 24 max. 108 drilling and tapping  
 3 spindles on line for spring collets min. 24+24 max. 66+66 with shank ISO 40  
 4 spindles for spring collets min. 53,5 max. 137,5 with shank ISO 40  
 3 spindles for spring collets min. 53,5 max. 137,5  
 2 spindles for spring collets min. 56 max. 148  
 2 spindles DIN 55058-12 min. 56 max. 148  
 2 spindles for spring collets min. 28 max. 120 with shank ISO 40  
 2 spindles for spring collets min. 28 max. 120 ratio 1-2  
 2 spindles for spring collets min. 28 max. 120 drilling and tapping  
 2 spindles for spring collets min. 128 max. 220  
 2 spindles for spring collets min. 208 max. 300  
 4 spindles at 90° DIN 55058-12 min. 60 max. 152 ratio 1-2  
 4 spindles at 90° for spring collets min. 60 max. 152 with shank ISO 50  
 2 spindles for spring collets min. 70 max. 186  
 2 spindles DIN55058-16 min. 70 max. 186  
 2 spindles DIN55058-16 min. 35 max. 151 with shank ISO 50  
 2 spindles for spring collets min. 35 max. 151 with shank ISO 50  
 2 spindles diam. 12 min. 35 max. 151  
 2 spindles DIN 55058-16 min. 144 max. 260  
 4 spindles at 90° for spring collets, min. 75 max. 191 with shank ISO 50  
 1 spindle diam. 16, min. 16,5 max. 82,5 ratio 1-2  
 2 spindles for spring collets, min. 82 max. 214  
 2 spindles DIN 55058-28 min. 82 max. 214  
 2 spindles diam 16, min. 41 max. 173  
 2 spindles for spring collets, min. 41 max. 173 with shank ISO 50  
 2 spindles for spring collets, min. 41 max. 173 ratio 1-2  
 2 spindles DIN 55058-28, min. 41 max. 173 ratio 1-2  
 3 spindles diam.16 min. 41+41 max. 107+107  
 2 spindles DIN 55058-36, min. 110 max. 294

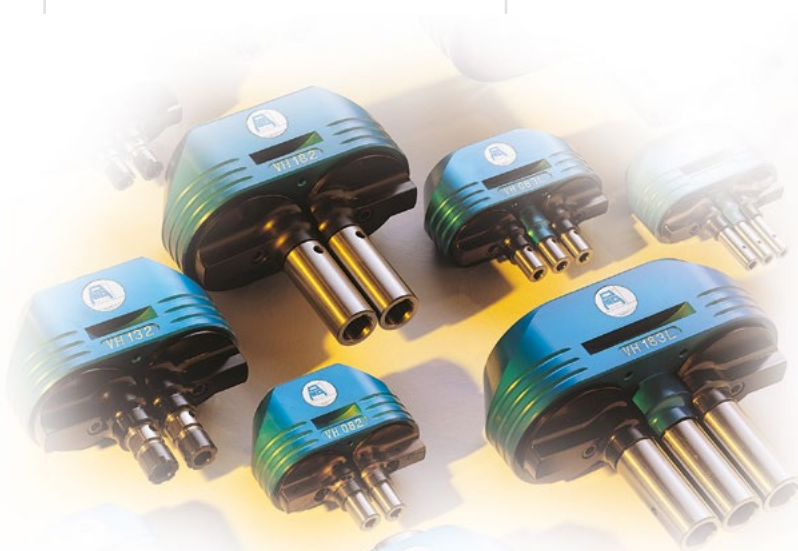

ESECUZIONI SPECIALI  
 SPECIAL EXECUTIONS

FH  
 BAH  
 TA,CP  
 TA  
 MOX  
 HT  
 7-20  
 VH  
 TSI/TSX  
 T  
 MT-TC-TC3





# VH

GALLERY





